

The GreenPeak Technologies GP510 System-on-Chip is an RF4CE network communications controller for integration into an RF4CE target or controller node. It is optimized for low cost while providing superior performance. The integrated RF filtering simplifies the RF design complexity enabling low cost single layer applications using simple PCB antennas requiring no shielding and a minimum number of external components. The embedded ZigBee RF4CE network layer enables fast and simple integration.

The chip is fully compliant with the IEEE 802.15.4 standard, providing robust spread spectrum data communication with a highly secure encrypted data flow. Its superior Wi-Fi interference robustness and antenna diversity offer additional robustness in a crowded wireless 2.4 GHz environment.

The GP510 is configurable, provides a serial interface (SPI, TWI or UART-based) to the main processor. The GP510 has an extreme low standby power enabling total system power consumption of less than 1 mW while allowing reception of remote control commands.

### Chip Overview

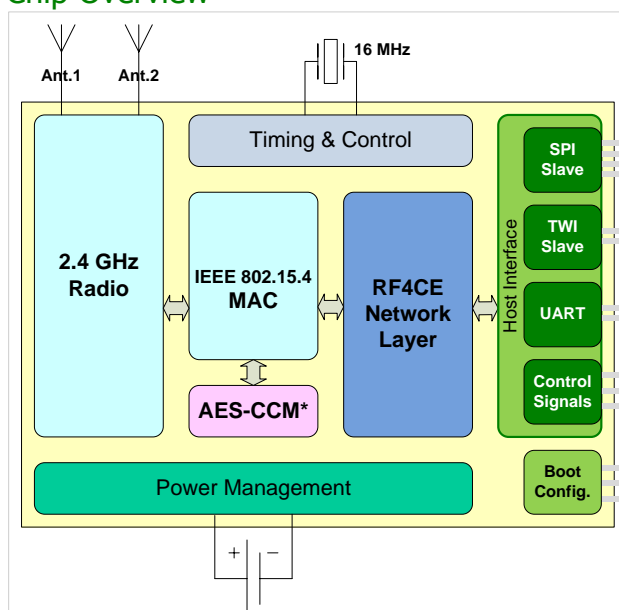

### Low Cost

The GP510 RF4CE communication controller is designed to operate on very low cost, single layer, paper phenol like PCB material using only low cost components and printed circuit antennas. No expensive Low Pass filters, baluns, shielding or chip antennas are required. The device only requires a low cost 16 MHz crystal and supply decoupling capacitors.

### Excellent Range and Reliability

The GP510 has been optimized for reliable communication in harsh radio environments. The excellent receiver sensitivity allows extended coverage. Built-in antenna diversity with two antennas improves the reliable link budget by 9 dB resulting in approximately twice the reliable range compared to similar systems with only one antenna. In high density networks the packet-in-packet resynchronization further improves the communication reliability. The potential risks of interference by Wi-Fi and/or Bluetooth devices have been reduced by the combination of excellent receiver dynamic range and an auto tuned band-pass filter.

### Reference Designs and Tools

GreenPeak Technologies reference designs and development and production platforms provide a quick time-to-market solution for RF4CE Remote Control products.

### Key Features

- Ultra low cost single layer, paper phenol, PCB design, requiring no shielding, LP filters, baluns or chip antennas
- IEEE 802.15.4 compliant
- Operates in the worldwide 2.4 GHz ISM-band
- Excellent range by antenna diversity: 9 dB more reliable link budget compared to single antenna systems
- 30 dB better robustness to Wi-Fi Interference
- Hardware accelerated AES-128 CCM\* security mode with automatic encryption, decryption and authentication
- Integrated ZigBee RF4CE network layer
- Suitable for Target or Controller node
- Selectable serial host interface: UART, TWI or SPI Slave

GreenPeak Technologies is a fabless semiconductor company offering innovative ultra low power wireless and battery-free data communication technologies for consumer electronics and sense and control applications.

## Electrical Characteristics

Standby Mode Currents <sup>1</sup>	
Untimed	
Event Driven	200 nA
Timed	
Using 16 MHz crystal	600 $\mu$ A
Operational Currents <sup>1</sup>	
Receive	22 mA
Transmit	20 mA (at 0 dBm)
Supply Voltage <sup>1</sup>	
Regulated	2.1 to 3.6 V
Interfaces	UART TWI Slave SPI Slave
Crystal Frequency	
Operational	16.000 MHz ( $\pm$ 40 ppm)

## General Characteristics

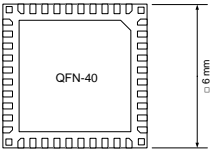
Package	QFN-40, 6x6 mm
	
Operating Temperature	-40 to +85°C (industrial)
Storage Temperature	-55 to +150°C
Soldering Temperature	250°C (10 s max)
Compliance	RoHS

## Radio Characteristics

Standards	IEEE802.15.4-2003 IEEE802.15.4-2006
Radio Regulations	ETSI EN 300 328 FCC CFR-47 Part 15 ARIB STD-T66
Frequency Band	2400 – 2483.5 MHz
Channels	3 (standard RF4CE channels) with frequency agility
Modulation	IEEE802.15.4
Chip rate	2 Mchip/s
Data Rate	250 kbit/s
Receiver Sensitivity <sup>1</sup>	-92 dBm typical -101 dBm <sup>2</sup>
Antenna diversity gain <sup>3</sup>	9 dB
Co-channel Rejection	> -2.5 dB
Adjacent Channel Rejection	> 30 dB
Alt. Adjacent Channel Rejection	> 45 dB
Wi-Fi IEEE 802.11g Rejection <sup>4</sup>	> 30 dB
Bluetooth Rejection <sup>5</sup>	> 25 dB
Transmit Power	+3 dBm (adjustable down in 1 dB steps)
Radio Management	Antenna Diversity Digital RSSI Link Quality Indication

1) At 3.0V and 25°C, unless specified otherwise.

2) Compared to systems without Antenna Diversity

3) For typical indoor usage in an environment with 50 ns delay spread and 2 MHz signal bandwidth using the Rayleigh fading model: antenna diversity with 2 antennas results in a 9 dB improved link budget at a 1% outage probability compared to no antenna diversity. The 9 dB in link budget translates into 80% more range, if using a two slope range model with the breakpoint at 10m and  $g_1 = 2$ ,  $g_2 = 3.5$ .

4) At +12 MHz and -13 MHz.

5) At +4 MHz and -4 MHz.