

The GP530 System-on-Chip is an RF4CE communication controller for integration into a TV Front Panel. It is optimized for low cost while providing superior performance. It allows for single-layer PCB front panel integration and the embedded ZigBee RF4CE network and ZRC profile (target) layers enable fast and simple integration. The programmable host interface provides flexibility for the communication protocol with the main processor.

The chip is fully compliant with the IEEE 802.15.4 standard, providing robust spread spectrum data communication with a highly secure encrypted data flow. Its superior Wi-Fi interference robustness and antenna diversity offer additional robustness in a crowded wireless 2.4 GHz environment. The GP530 is configurable, provides a UART serial interface to the TV's main processor, and supports front panel buttons. The GP530 is equipped to handle the power management of the TV and has an extreme low standby power enabling total system power consumption of less than while allowing reception and interpretation of remote control commands to switch on the main system.

Chip Overview

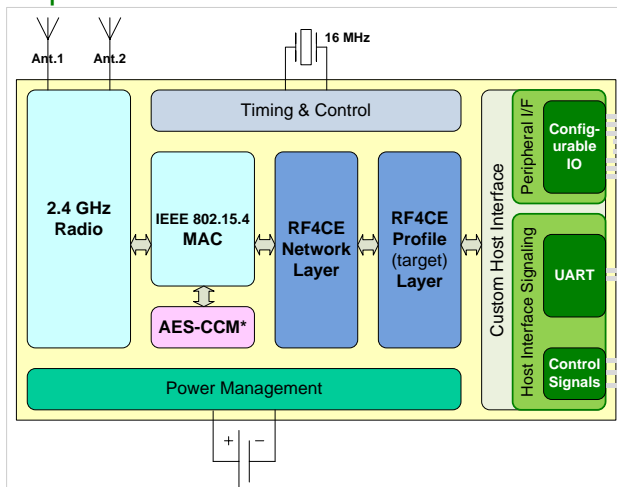

Key Features

- Ultra low cost single layer, paper phenol, PCB design, requiring no shielding, LP filters, baluns or chip antennas
- IEEE 802.15.4 compliant
- Operates in the worldwide 2.4 GHz ISM-band
- Hardware accelerated AES-128 CCM* security mode with automatic encryption, decryption and authentication
- Integrated configurable ZigBee RF4CE network and ZRC profile (target) layers
- Excellent range by antenna diversity: 9 dB more reliable link budget compared to single antenna systems
- Additional improved robustness by packet-in-packet resynchronization
- 30 dB better robustness to Wi-Fi Interference
- UART Serial Interface; programmable protocol
- Support for front panel buttons, lights and display
- Handles the power management of the main system

Low Cost

The GP530 RF4CE communication controller is designed to operate on very low cost, single layer, paper phenol like PCB material using only low cost components and printed circuit antennas. No expensive Low Pass filters, baluns, shielding or chip antennas are required. The integrated RF4CE network and ZRC profile layers greatly reduce the BOM. The device only requires a low cost 16 MHz crystal and supply decoupling capacitors.

Excellent Range and Reliability

The GP530 has been optimized for reliable communication in harsh radio environments. The excellent receiver sensitivity allows extended coverage. Built-in antenna diversity with two antennas improves the reliable link budget by 9 dB resulting in approximately twice the reliable range compared to similar systems with only one antenna. In high density networks the packet-in-packet resynchronization further improves the communication reliability. The potential risks of interference by Wi-Fi and/or Bluetooth devices have been reduced by the combination of excellent receiver dynamic range and an auto tuned band-pass filter.

Configuration

The GP530 has integrated RF4CE network and ZRC profile (target) layers that can be customized in the production line with application-specific parameters like ZRC profile attributes and interface parameters.

Reference Designs and Tools

GreenPeak Technologies reference designs and development and production platforms provide a quick time-to-market solution for RF4CE Remote Control products.

GreenPeak Technologies is a fabless semiconductor company offering innovative ultra low power wireless and battery-free data communication technologies for consumer electronics and sense and control applications.



GreenPeak Technologies B.V.
The Netherlands
+31 (30) 262 1157
info@greenpeak.com
www.greenpeak.com

GP530 RF4CE Communication Controller for TV

Electrical Characteristics

Standby Mode Currents ¹	
Untimed	
Event Driven	200 nA
Timed	
Using 16 MHz crystal	600 µA
Operational Currents ¹	
Receive	22 mA
Transmit	20 mA (at 0 dBm)
Supply Voltage ¹	
Regulated	2.1 to 3.6 V
Interfaces	
	UART TX/RX 13 configurable IO lines
Crystal Frequency	
Operational	16.000 MHz (±40 ppm)

General Characteristics

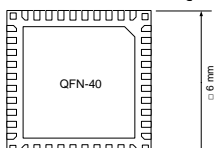
Package	QFN-40, 6x6 mm
	
Operating Temperature	-40 to +85°C (Industrial)
Storage Temperature	-55 to +150°C
Soldering Temperature	250°C (10 s max)
Compliance	RoHS

Radio Characteristics

Standards	IEEE802.15.4-2003 IEEE802.15.4-2006
Radio Regulations	ETSI EN 300 328 FCC CFR-47 Part 15 ARIB STD-T66
Frequency Band	2400 – 2483.5 MHz
Channels	3 (standard RF4CE channels) with frequency agility
Modulation	IEEE802.15.4
Chip rate	2 Mchip/s
Data Rate	250 kbit/s
Receiver Sensitivity ¹	-92 dBm typical -101 dBm ²
Antenna diversity gain ³	9 dB
Co-channel Rejection	> -2.5 dB
Adjacent Channel Rejection	> 30 dB
Alt. Adjacent Channel Rejection	> 45 dB
Wi-Fi IEEE 802.11g Rejection ⁴	> 30 dB
Bluetooth Rejection ⁵	> 25 dB
Transmit Power	+3 dBm (adjustable down in 1 dB steps)
Radio Management	Antenna Diversity Digital RSSI Link Quality Indication

1) At 3.0V and 25°C, unless specified otherwise.

2) Compared to systems without Antenna Diversity

3) For typical indoor usage in an environment with 50 ns delay spread and 2 MHz signal bandwidth using the Rayleigh fading model: antenna diversity with 2 antennas results in a 9 dB improved link budget at a 1% outage probability compared to no antenna diversity. The 9 dB in link budget translates into 80% more range, if using a two slope range model with the breakpoint at 10m and g1 = 2, g2 = 3.5.

4) At +12 MHz and -13 MHz.

5) At +4 MHz and -4 MHz.

This document is the property of GreenPeak Technologies

Reproduction or disclosure in whole or in part to parties other than the GreenPeak Technologies client or partner who is the original receiver of this document is permitted only with the written and express consent of GreenPeak Technologies B.V.