

The GP540 is an RF4CE communication controller for integration into a Remote Control. It is optimized for low cost while providing superior performance. It allows for single-layer PCB integration and the embedded ZigBee RF4CE network and ZRC profile (controller) layers enable fast and simple integration. The chip is fully compliant with the IEEE 802.15.4 standard, providing robust spread spectrum data communication with a highly secure encrypted data flow. Its superior Wi-Fi interference robustness and antenna diversity offer additional robustness in a crowded wireless 2.4 GHz environment.

The GP540 includes a configurable Keyboard Scanner, as well as an IR interface for compatibility with legacy targets, enabling a single chip low cost solution for remote control devices in the CE market. The serial interface (SPI or TWI) provides connectivity to an optional host processor.

The GP540's unique ultra low power technique with an extreme low power mode optimized for remote controls, enables the device to run on a single coin cell battery for a decade or more without ever having to replace or recharge it, so it essentially becomes maintenance free.

Chip Overview

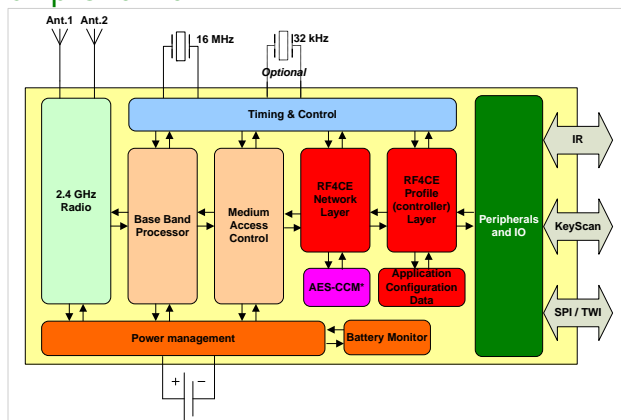

Key Features

- Maintenance free ZigBee RF4CE Remote Control applications
- Ultra low cost single layer, paper phenol, PCB design, requiring no shielding, LP filters, baluns or chip antennas
- IEEE 802.15.4 compliant
- Operates in the worldwide 2.4 GHz ISM-band
- Hardware accelerated AES-128 and AES-256 CCM* security mode with automatic encryption, decryption, authentication
- Integrated configurable ZigBee RF4CE network and ZRC profile (controller) layers
- Low Leakage RAM
- Excellent range by antenna diversity: 9 dB more reliable link budget compared to single antenna systems
- Additional improved robustness by packet-in-packet resynchronization
- 30 dB better robustness to Wi-Fi Interference
- Support for external PA and LNA
- Advanced Energy Management, supporting intermitted energy sources and coin cell battery operation
- Integrated Keyboard Scanner with ultra low power wake up on key press, keyboard scan and debounce
- Infra-Red (IR) interface for dual-mode operation
- SPI or TWI Serial Interface to an optional host processor

Low Cost

The GP540 RF4CE communication controller is designed to operate on very low cost, single layer, paper phenol like PCB material using only low cost components and printed circuit antennas. No expensive Low Pass filters, baluns, shielding or chip antennas are required to design a high performance Remote Control application. The integrated RF4CE network and ZRC profile layers greatly reduce the BOM. The device only requires a low cost 16 MHz crystal and supply decoupling capacitors.

Excellent Range and Reliability

The GP540 has been optimized for reliable communication in harsh radio environments. The -94 dBm receiver sensitivity allows extended coverage. Built-in antenna diversity with two antennas improves the reliable link budget by 9 dB resulting in approximately twice the reliable range compared to similar systems with only one antenna. In high density networks the packet-in-packet resynchronization further improves the communication reliability. The potential risks of interference by Wi-Fi and/or Bluetooth devices have been reduced by the combination of excellent receiver dynamic range and an auto tuned band-pass filter.

Configuration

The GP540 has integrated RF4CE network and ZRC profile (controller) layers that can be customized in the production line with application-specific parameters like keyboard layout, key code assignments, IR codes, ZRC profile attributes, interface parameters, power management options, etc.

GreenPeak Technologies is a fabless semiconductor company offering innovative ultra low power wireless and battery-free data communication technologies for consumer electronics and sense and control applications.



GreenPeak Technologies B.V.
The Netherlands
+31 (30) 262 1157
info@greenpeak.com
www.greenpeak.com

Ultra Low Power, Maintenance Free

The GP540 is designed for ultra low power Remote Control applications and can run, maintenance free, on a standard lithium coin cell battery, like the CR2032, allowing for very small form factor products. The battery lifetime monitor tracks the usage of the battery and provides an early exhaustion warning. With an ultra low leakage current during standby mode, keyboard scan and very low peak currents during receive and transmit, the battery life can exceed 10 years depending on the application.

Advanced Integrated Energy Management

The GP540 has an advanced integrated energy management system, which allows it to operate from a coin-cell battery as well as from intermittent power supplies like photovoltaic (solar), electro-mechanical and piezoelectric, with a minimum of additional components.

The Energy Management system includes ultra low power voltage level detectors and overvoltage protection circuitry, allowing safe operation and graceful shutdown.

Reference Designs and Tools

GreenPeak Technologies reference designs and development and production platforms provide a quick time-to-market solution for RF4CE Remote Control products.

Electrical Characteristics

Standby Mode Currents ¹		
Untimed		
Event Driven		200 nA
Timed		
Using	32 kHz crystal	300 nA
	16 MHz crystal	600 µA
Operational Currents ¹		
Receive		22 mA
Transmit		20 mA (at 0 dBm)
Supply Voltage ¹		
Regulated		2.1 to 3.6 V
Interfaces		
		SPI or TWI
		17 GPIO lines
		(8 Wake-on-change)
		External LNA/PA control
Crystal Frequencies		
Operational		16.000 MHz (±40 ppm)
Standby (optional)		32.768 kHz (±40 ppm)

General Characteristics

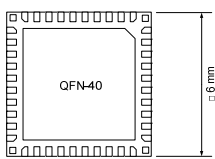
Package	QFN-40, 6x6 mm
	
Operating Temperature	-40 to +85°C (industrial)
Storage Temperature	-55 to +150°C
Soldering Temperature	250°C (10 s max)
Compliance	RoHS

Radio Characteristics

Standards	IEEE802.15.4-2003 IEEE802.15.4-2006
Radio Regulations	ETSI EN 300 328 FCC CFR-47 Part 15 ARIB STD-T66
Frequency Band	2400 – 2483.5 MHz
Channels	16 (programmable 5 MHz step size)
Modulation	IEEE802.15.4
Chip rate	2 Mchip/s
Data Rate	250 kbit/s
Receiver Sensitivity ¹	-92 dBm typical -101 dBm ²
Antenna diversity gain ³	9 dB
Co-channel Rejection	> -2.5 dB
Adjacent Channel Rejection	> 30 dB
Alt. Adjacent Channel Rejection	> 45 dB
Wi-Fi IEEE 802.11g Rejection ⁴	> 30 dB
Bluetooth Rejection ⁵	> 25 dB
Transmit Power	+3 dBm (adjustable down in 1 dB steps)
Radio Management	Antenna Diversity Digital RSSI Link Quality Indication

1) At 3.0V and 25°C, unless specified otherwise.

2) Compared to systems without Antenna Diversity

3) For typical indoor usage in an environment with 50 ns delay spread and 2 MHz signal bandwidth using the Rayleigh fading model: antenna diversity with 2 antennas results in a 9 dB improved link budget at a 1% outage probability compared to no antenna diversity. The 9 dB in link budget translates into 80% more range, if using a two slope range model with the breakpoint at 10m and $g_1 = 2$, $g_2 = 3.5$.

4) At +12 MHz and -13 MHz.

5) At +4 MHz and -4 MHz.